

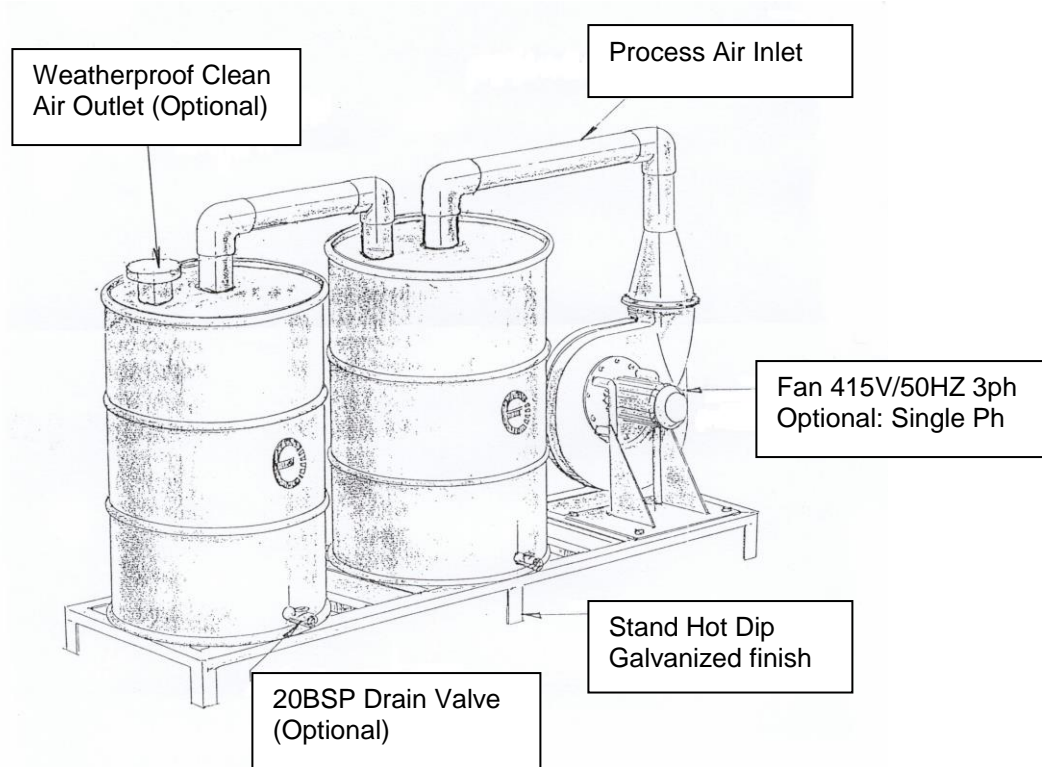

The Environmental Group Limited
Delivering Innovative Environmental Solutions

ACTIVATED CARBON CANISTERS - DUPLEX



- Each Odour-Miser canister contains 68kg of Activated Carbon, selected to suit specific applications for pollution/odour control
- Maximum process air flow for treatment : 680 m³/hr
- Shipping weight : 220kg (approx)
- Options available : outlet duct, single ph motor.
- Inlet connection (and optional outlet duct) 100N.B. pipe.
- All Dimensions are typical only.

