

ACTIVATED CARBON CANISTERS - QUAD

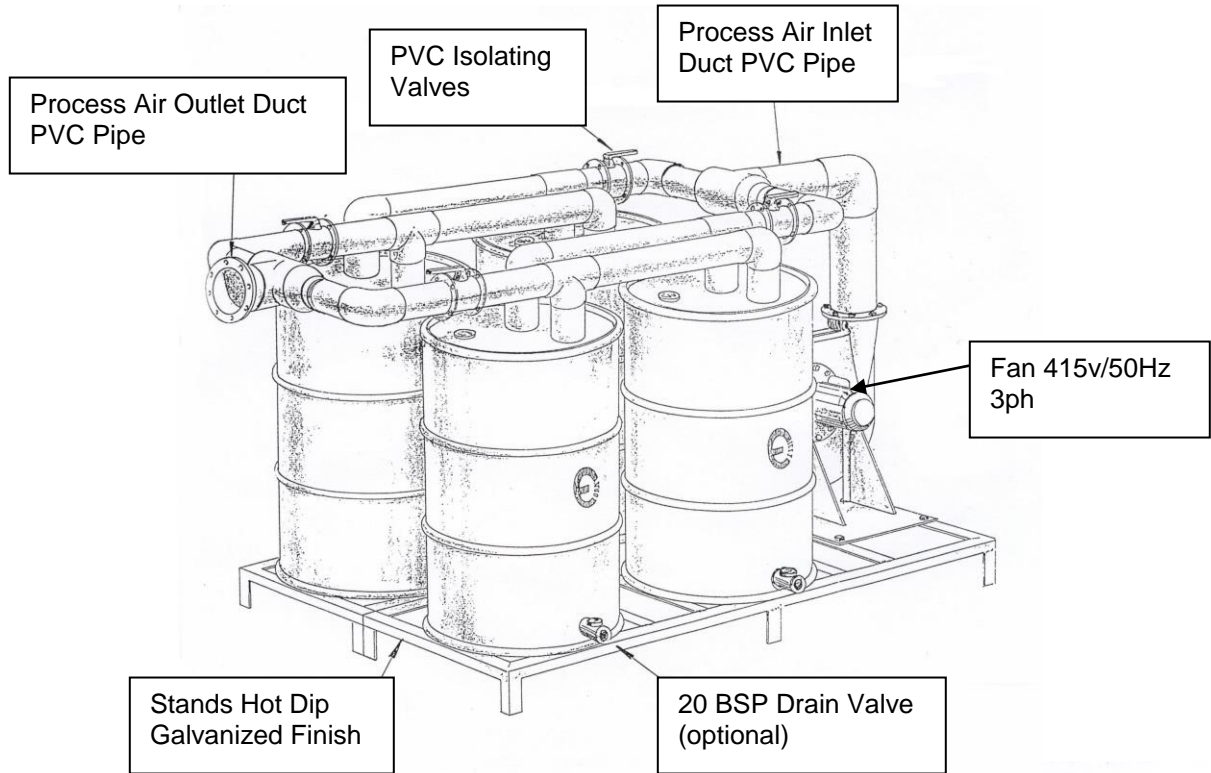

- Each Odour-Miser canister contains 68kg of Activated Carbon
- Maximum process air flow for treatment : 1360m³/hr
- Shipping weight : 400kg (approx)
- All Dimensions are typical only

